



### BUCKET ELEVATOR SPECIFICATIONS

MODEL	MAJOR II-50	MAJOR II-60	MAJOR II-60
(1) Capacity in Bu/hour	5000	6000	7000
Belt Speed F.P.M.	550	550	565
Head Pulley R.P.M.	70	70	72
Bucket Spacing	12"	10"	9"
Bucket Size		15" x 7"	
Head Pulley Size		30" Dia. X 16" Face	
Head Shaft Dia.		See Head Shaft Dia. Chart	
		Page 10	
Boot Shaft Dia.		1-15/16"	
Head Casing		11, 12 & 14 Gauge	
Boot Casing		10 Gauge	
Legging		12 Gauge	
Recommended Spouting	10"	12"	10"
Bearings		Roller Bearing, Pillow Block	
Belt Size		P.V.C. 16" Wide	

(1) @75% Cup Filling

#### Dimensions

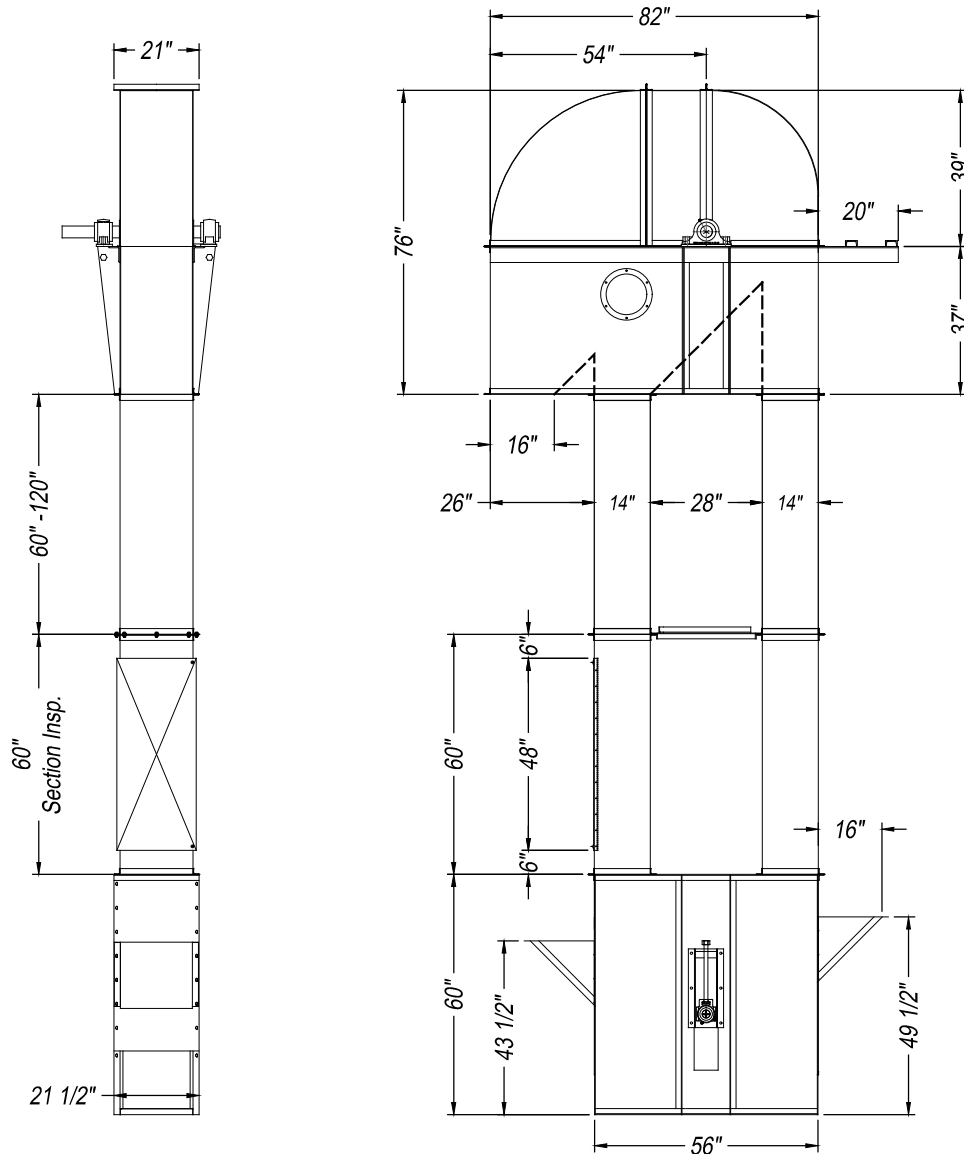

MAJOR II BUCKET ELEVATOR

Scale: 1/4" = 1'